

EASYBIKE MI5

USER MANUAL AND
WARRANTY CARD



EASYBIKE MI5
STUDY CAREFULLY BEFORE DRIVING!

 **EasyBike**
elektrokola

1.YOUR NEW ELECTRIC BIKE.....	3
1.1. Home	3
1.2. General performance	3
2.WHEEL MAINTENANCE.....	4
2.1. Settings	4
2.2. Safety instructions before driving	4
2.3. Rear wheel mounting and adjustment	5
2.4. Suspension fork	5
2.5. Driving in bad weather	6
3. ELECTROSADA	6
3.1. Batteries	6
3.1.1. Removing and installing the battery	6
3.1.2. Charging	6
3.1.3. Important notices	7
3.1.4. Normal battery behaviour	7
3.1.5. Storage	7
3.1.6. Driving distance factors	8
3.2. Control display	9
3.2.1. Button layout/display fields	9
3.2.2. Display control	9
4.SAFETY INFORMATION	12
4.1. Ensuring safe operation	12
4.2. Maintenance	13
4.3. Notice	14
5.WARRANTY CERTIFICATE AND WARRANTY INSPECTION	14
5.1. Warranty conditions	14
5.2. Warranty inspection	18
5.3. Warranty Card	18



1. Your new electric bike

1.1. INTRODUCTION

Dear Customers, Thank you for purchasing our EasyBike electric bike. We believe that our bike will bring you a lot of joy and experience. Please read this manual carefully to ensure the proper functioning of the bike and your satisfaction. Keep in mind that the e-bike and its mechanical and electrical components require regular maintenance and the batteries require appropriate storage.

The bicycle is equipped with an electric motor to assist you in pedaling. However, the motor cannot be used as the sole and exclusive drive of the e-bike. You can also set the e-bike in motion using the control button, but only up to the maximum speed of 6 km/h (e.g. as a walking aid). The maximum speed of the motor-assisted e-bike is 25 km/h with a tolerance of 5% (when you reach this speed, the motor switches off and you continue pedalling as on a normal bicycle). When the battery runs out or the engine is switched off, you can ride the e-bike as a normal bicycle without any resistance. An electric bicycle that complies with the European standard EN 15194 in terms of its characteristics is regarded as a normal bicycle for the purposes of the Road Traffic Act. This means that you can ride on cycle paths, you don't need a driving licence and a helmet is only compulsory up to the age of 18. By using bikes and e-bikes, you save the environment by not creating harmful emissions or otherwise polluting your surroundings.

Have a nice ride.

1.2. GENERAL INTRODUCTION TO ELECTRIC BIKES

BASIC TECHNICAL INFORMATION

Total bike weight: 24.5 kg including battery

Maximum total weight: 125 kg (weight of bike, rider and load) Maximum assisted speed: 25 km/h

BASIC COMPONENTS:

Frame: 27,5", Al 6061

Battery: 36 V / 13 Ah, Li-Ion

Motor: Bafang 8FUN, 250 W

Display: Das-Kit C7

Fork: SUNTOUR XCM 27,5", 100 mm travel, lockable

Brakes: TEKTRO, mechanical, disc

Shifting: SHIMANO Altus, 3 × 7 gears

Shifting: SHIMANO Tourney, 7st. Tires:

SCHWALBE, 27.5 × 2.25

DECLARATION OF CONFORMITY

EasyBike e-bikes meet all applicable requirements for road use and are manufactured in accordance with EN 15194.

All used electrical components are always separately marked with the CE symbol according to the valid and required standards.

If any changes are made to the EasyBike without the prior consent of AutoKelly a.s., this declaration shall become void.



Manufacturer of electric bikes EasyBike

AutoKelly a.s., Ocelářská 16, Prague 9, 190 00, Czech Republic

2. Service bikes

2.1. SEATING SETUP

Saddle height adjustment Release the quick-release lever and adjust the seat height to the desired level. **However, do not exceed the maximum extension level** marked on the seat tube. Doing so could either damage the seat or to break out of the frame. After adjustment, reverse the lever to secure the quick release.



Příliš nízko nastavené sedlo



Příliš vysoko nastavené sedlo



Optimálně nastavené sedlo

The saddle height should be set so that the rider's leg is slightly bent at the knee when the pedal is in the down position. At the same time the user can adjust the saddle in the forward direction and its inclination.

2.2. SAFETY INSTRUCTIONS BEFORE, DURING AND AFTER THE RIDE

Make sure the front and rear brakes are working properly by pressing both brake levers and pushing the bike forward. When squeezing, the lever must not touch the handlebars. Also make sure that the disc does not touch the pads, there must always be a small gap between the disc and the pad. It is also important to check the wear on the brake pads continuously. Avoid any contact of the disc and pads with greasy preparations for the maintenance of other parts of the e-bike.

Also, check the tyre pressure before each ride (the recommended pressure is shown on the side of the tyre) and there should be no bulge or cracks. Check that the wheels are correctly seated in the beads and the quick release fasteners are tightened correctly. When spinning the front wheel and then the rear wheel, check the centring of the rim.

Ensure that all quick-release, screw and similar connections are tightened securely. There must also be no play in the wheel, particularly in the head assembly, wheel hubs and pedal centre. During operation of the bicycle, some elements may become partially loose and, if this occurs, the elements concerned must be tightened.

Keep the chain and other drive train components clean. Lubricate the chain regularly with the products intended for this purpose. It is recommended to carry a service kit consisting of a spare inner tube, mounting pin, glue, pump and a set of basic tools. The bike is designed for recreational riding in moderate terrain, on cycle paths, gravel, dirt and forest roads.

The bike is definitely not designed for excessively rough handling, such as jumping, crossing higher obstacles or downhill and similar disciplines.

Observe the rules of safe driving on roads laid down by generally binding legal regulations. Remember that a cyclist is a full-fledged road user who is subject to the same rules as the driver of a motor vehicle. The bicycle is equipped with reflective elements for daytime riding. For riding at night or in reduced visibility, lighting must be used as defined by the current law. Clean the bike after riding and store it dry. Shift to the smallest pinion at the rear. Remove the battery. If you will be using your e-bike frequently, we recommend that you pay more attention to checking the individual components as they may be subject to more wear and tear. Do not modify the bike in any way to maintain your personal safety.

2.3.SUSPENSION FORK

The damping stiffness of the fork can be adjusted by a wheel on the left fork leg. There is a lock on the right leg. This allows you to unlock and lock the fork suspension. The lock leaves a small clearance to the suspension to prevent damage to the locking mechanism.

- Keep the fork slides clean.
- After each ride, wipe the gliders clean of dust and spray silicone oil on the bearings.

When riding off-road, always keep the fork unlocked (this means it must be spring loaded - this will prevent damage to the locking mechanism).

If you are unsure about anything, contact your local AUTO KELLY branch or contract service for information or expert assistance.

2.4.REAR WHEEL MOUNTING AND ADJUSTMENT

For transport or servicing, you may need to dismantle a bike with a tangled motor.

- First, disconnect the motor connector, which is located approximately 10 cm from the motor inlet.
- Shift to the smallest pinion.
- Loosen the motor nuts with a spanner #18 and remove the wheel from the feet.
- When reassembling, proceed in the exact reverse order.
- When fitting the wheel with the motor engaged, ensure that the centre axle is in the correct position, i.e. recessed downwards. The cable must enter the motor from the bottom. Otherwise, water could enter the motor and damage it.
- When connecting the connector, make sure that the arrows on both parts of the connector are facing each other. Connect the connector with firm force. Insufficient insertion may cause the motor to malfunction or damage the connector.

If you are unsure about anything, please contact your dealer for information or professional help.

2.5. RIDING IN BAD WEATHER

In light rain, the ride doesn't matter. However, it is not advisable to leave or park your bike where it is not protected against rain, snow and sun.

3. Elektrosada

3.1. BATTERIES

36 V / 13 Ah, Li-Ion technology, Samsung cells

3.1.1. REMOVING AND INSTALLING BATTERY

To remove the battery, it must be released using the lock above the battery. Tilt the battery towards the bottom and back and separate it from the frame. Install the battery in the reverse sequence of the above procedure. The click of the lock indicates the battery is secured. Check that the battery is firmly in its compartment.

3.1.2. CHARGE

The battery is one of the most expensive parts of an e-bike, so please pay extra attention to its handling, charging and storage. Always use only the original charger.

Plug the charger into a 220V socket and then plug the charger connector into the battery. The socket is located on the bottom of the battery. We recommend that you fully charge the battery after each ride to ensure that you have full battery capacity for your next trip. Depending on the state of the battery cells, it can take up to 5 hours to charge the battery. It should be carried out in a dry area, ideally at a temperature between 5 and 40 °C. The charging process is indicated by a red LED on the charger. When the battery is charged and the charging process is complete, it will light up green.

The battery contains a charge indicator light (the charge indicator light comes on when the charge indicator button is pressed). After driving, make sure the display is switched off.

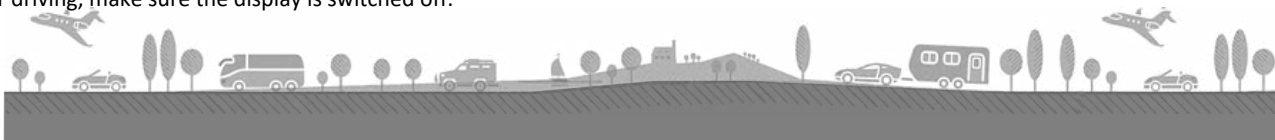
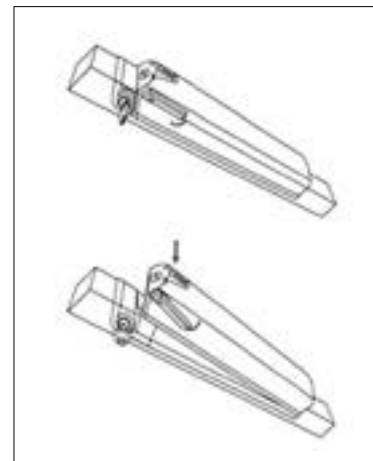

IMPORTANT NOTICES!

- Charge the battery in a dry environment to prevent damage from short circuits.
- Charge the battery ideally once every 2 months, even when the bike is not in use, to at least 60% capacity.
- Do not cover the battery or charger. Overheating could occur.
- Do not leave the battery connected to electricity at all times.
- Do not use the battery for other appliances. It is made exactly for this model.
- Do not disassemble or modify the battery case.
- Do not throw the battery into fire or expose it to extreme temperatures.

3.1.3. NORMAL BATTERY BEHAVIOUR

If the engine stops running smoothly and starts running "jerkily", the battery may be too low. In this case, switch off the electric drive system and continue without motor assistance as on a normal bicycle. Battery overheating is a common occurrence and is not a fault. The battery is protected by a temperature sensor and will automatically switch off in the event of excessive overheating. Wait until the battery has cooled to normal operating temperature and continue riding. If you feel that the overall battery capacity has dropped, this could be due to charging or operation in non-ideal weather conditions. Perform 3 full recharge cycles. Fully discharge the battery by driving and then recharge it to full capacity at room temperature.

3.1.4. STORAGE

Store the battery in a dry and ventilated place away from direct sunlight and other heat sources. In case of cold storage, the battery must first be allowed to warm up to normal room temperature (20 °C) before being put into operation.

Li-Ion batteries are fully recyclable. At the end of its useful life, you can drop the battery off at any collection point or at your dealer.

Never leave the battery fully discharged, as it could be permanently damaged.



3.1.5. DISTANCE FACTORS

Tyre rolling resistance

Correct tyre inflation is important. If you have under-inflated tyres on your e-bike, for example, your range will be reduced and there is a risk of a puncture.

Weight of the electric bike

The lower the weight of the e-bike, the longer the range.

Battery status

It depends on whether the battery was fully charged before the journey. You should also take into account that the higher the number of discharge cycles the battery has had, the lower its capacity.

Profile and surface of the route

The higher the elevation, the worse the surface and the steeper the hills, the shorter the range.

Driving mode

It depends on which of the driving modes you have set when driving.

Driving smoothness

The more you brake or accelerate, the shorter the range.

Air resistance

It depends on the position you take on the bike. If you are upright, you have more resistance, which results in a shorter range.

The power of the wind

The stronger the wind at your back, the longer the range and vice versa.

Weight of rider and load

The greater the weight, the shorter the range.

External temperature

The lower the temperature, the lower the battery capacity.

PROPER CARE OF THE BATTERY EXTENDS ITS LIFE.



3.2. Control display

3.2.1. BUTTON/FIELD LAYOUT DISPLAY

Changing assistance -
plus ON/OFF Changing
indicators
Change of assistance - minus

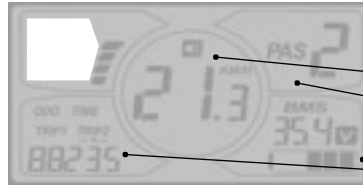

The following indicators are standard on the display when it's switched on: cruising speed, assistance level indicator, battery indicator, distance and travel time display.

3.2.2. CONTROL DISPLAY

1. ON/OFF

Press the ON/OFF button to turn on the display. Press the ON/OFF button again to turn on the display backlight. Hold the ON/OFF button for at least 3 seconds to turn it off.

2. FULL DISPLAY



1. Assistance level indicator

To change the level of assistance, press the +/- buttons. The assist level can be set to 0-6 (0 - no assistance, 6 - highest possible level of assistance).

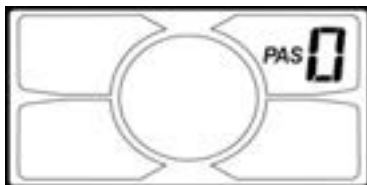

2. Display backlight

Press the ON/OFF button to activate the backlight when the display is on.

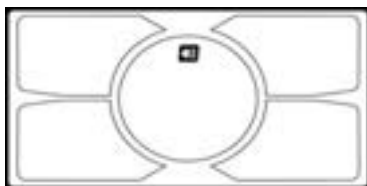

3. Error code

Contact your distributor if you see it. The error message will remain on the display until the fault is corrected.

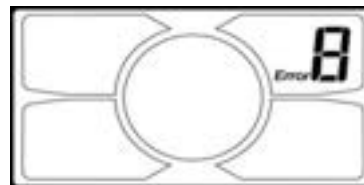

4. Speed indicator



5.6 km/h driving control without pedalling

Press and hold the "-" button. When the button is released, the mode is switched off.



6.Distance and travel time display

Press the SET button to switch between the ODO, Trip1, Trip2 and Time indicators.

ODO - total distance travelled indicator.

Trip1 - after 500 km, the display automatically resets to zero.

Trip2 - shows the last distance travelled by the e-bike, to reset, long press the SET button. Time - displays the travel time, to reset press the SET button for a long time.

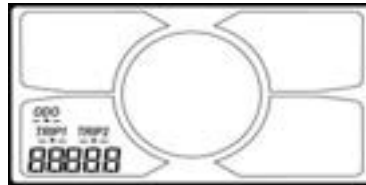

7.Battery voltage and capacity indicator

The battery capacity indicator has 5 segments, each segment representing 20% of the battery capacity.



8.Auto sleep function

The display automatically switches off if zero speed is displayed for more than 5 minutes.



4. Security information

4.1. ENSURING SAFE OPERATION

Conditions of operation The EasyBike Mi5 is designed for use on normal roads and light off-road terrain. It is not suitable for jumping or riding in water and is not equipped for heavy terrain.

Helmet

Always wear a protective bicycle helmet. Even falls at low speeds can lead to fatal head injuries!

Tyres

Regularly check the tread wear and inflation of the tyres. The prescribed tyre pressure is shown on the side of each tyre.

Handles and knitting

Regularly check the wheels and rims to make sure they are free of defects. Especially if there is a collision.

Lights and reflectors

Equip your bike with reflectors and lighting before you set off. Use lighting for riding in low visibility or at night.

Transfers

Keep pinions, shift pulleys and gearboxes clean. Lubricate only the chain for proper and quiet operation. An excessively stretched or otherwise damaged chain usually means that other parts that come into contact with it may also be damaged. **Warning sound signals** The bike makes no noise. Use the bell on the handlebars to signal your presence. Do not abuse it and use it only in the event of an imminent collision.

NOTICE

Like other mechanical devices, the bicycle is subject to stress and wear during its active operation. Some materials and components may react to this load, causing material fatigue and subsequent damage. If the service life of a part has been exceeded, sudden failure may occur, which may cause injury to the rider. If you find a crack or discoloration of the material in stressed areas, this may indicate that the life of the part has been exceeded and the part needs to be replaced.

4.2. MAINTENANCE

NOTICE Bike maintenance and repairs require specific experience and the right tools. Do not repair defects or make adjustments to the wheel if you have the slightest doubt about your ability to do the right thing. In this case, contact your dealer or a qualified service centre. Any repairs or adjustments that are not done properly may cause damage to the wheel or lead to injury. Use only original spare parts.

Cleaning

Before cleaning, remove the battery and prevent electrical equipment from coming into contact with water. Use detergent water and then wash the bike with clean water and dry. In winter, clean the e-bike and especially the battery contacts and other connectors of salt after each ride.

WARNING: DO NOT WASH THE WHEEL WITH A PRESSURE WASHER OR DIRECT WATER FROM THE HOSE.

Ecological disposal

Used parts must be disposed of environmentally and sorted for recycling. A battery that is no longer functional must be returned to the dealer or disposed of in an environmentally sound manner by a battery recycler.

Engine

The engine does not require any kind of maintenance.

Chain

The shifting chain and pulleys should always be lubricated. Use products in a dropper bottle designed for chain lubrication. Use of spray/aerosol can contaminate the discs and pads. **Transportation**

The battery does not need to be removed for transport in the car. If transporting on a car, we recommend removing the battery. The e-bike can be transported on a bike rack, taking into account the total weight of the bike and the load capacity of the bike rack. When transporting the e-bike on a towbar in rainy weather, we recommend covering the e-bike with a waterproof tarp to protect the battery and motor. When using a protective tarp, it is necessary to adjust the speed and driving style as its use can affect the aerodynamics and behaviour of the vehicle.

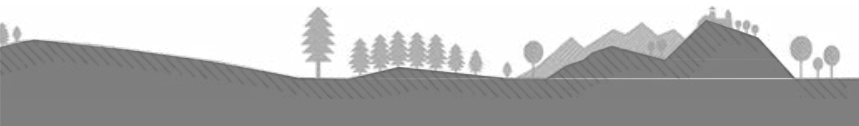

4.3. NOTICE

Do not lend an e-bike to persons who have not been instructed in its operation. Claims arising from improper handling will not be accepted. The e-bike should not be used by persons who are unable to pedal or handle it independently. The manufacturer is not responsible for any injury or damage to the e-bike! The ideal weather conditions for operating the e-bike are dry days when the outside temperature is above 10 °C. In the event of operation at lower temperatures, physical phenomena cause the battery to discharge more quickly. It is not recommended to operate the e-bike in outdoor temperatures below 0 °C. Do not expose the bike to direct sunlight, the bike has a thermal protection sensor for the electric drive. Never immerse the battery, charger or other electrical components in water or other liquids. Never pressure wash the e-bike and always remove the battery before washing. Do not interfere with the wiring of the electric motor, control unit or battery. Tampering will void the warranty or permanently damage the e-bike. Use only the original chargers and other components included in the package. Replacement parts are available in the manufacturer's e-shop.

5. Warranty certificate and warranty inspection

5.1. WARRANTY TERMS AND CONDITIONS

The warranty provided for the bicycles and components sold by us lasts for 2 years from the date of sale indicated in the warranty document or on the invoice, unless otherwise stated below for selected components. The warranty can be applied to manufacturing and hidden defects in the product caused by the manufacturer or the seller, in particular manufacturing defects in materials or defects caused by imperfect technological processing. The warranty does not cover defects caused by the purchaser due to non-compliance with the warranty conditions, including those in the user manual (e.g. conditions of use, maintenance and storage of the products), and defects caused by wear and tear in the normal use of the product (e.g. worn brake pads or worn tyres cannot be claimed). The lifetime of the product and the component depends on the use and maintenance and their service life.

The buyer is obliged to use and store the product according to the user manual and regularly perform proper maintenance, otherwise his right under the warranty expires.

The following are examples of which defects in the product and its components can be recognised as covered by the warranty in a claim procedure and which cannot, as well as some guidelines for the use, storage and maintenance of the product and components.

Further details regarding the Seller's obligations under the defective performance and the manner of exercising the rights under the defective performance by the Buyer (terms and conditions of the re-deception procedure) are set out in Auto Kelly's Terms and Conditions and Complaints Procedure, available at www.autokelly.cz.

Frames: In particular, a frame breakage due to a manufacturing or material defect that exists, even hidden, at the time of acceptance of the product by the buyer may be recognized as a legitimate claim. In particular, any mechanical damage caused by an accident, a fall or unprofessional adjustments to the frame geometry shall be considered an unjustified claim. Torn threads are not covered by the warranty. A frame that has been painted over cannot be accepted for claim.

Forks:

Defects such as looseness cannot be claimed if there is dirt and water inside the fork causing damage, or if the fork column is bent or the crown is damaged due to accidents and overloading. The condition for accepting a claim for a cracked suspension fork is that the geometry of the inner and outer legs is intact.

Wheels:

Complaints can be legitimately made for knitwear damaged by transport and manufacturing or material defects. Damage caused by wear and tear (e.g. rim puncture) and improper, unprofessional or rough handling (e.g. deformed rim) cannot be accepted in the claim procedure. The warranty does not cover bulging bearing raceways, dirt ingress into the idler housing and hub bearings or corroded parts. Operation of the bicycle requires checking and defining the clearance in the hub body.

Head composition:

The warranty covers manufacturing and material defects. Deformation of the fork columns when the stem is over tightened or deformation of the stem after extension beyond the maximum extension mark cannot be accepted as a legitimate claim. The operation of the bicycle requires the checking and defining of the headstock clearance. Warranty does not cover dislodged, corroded or contaminated bearing raceways.

The stem and handlebars:

The warranty covers manufacturing and material defects. Bending of handlebars and stem due to impact or fall or tearing of threads on stem due to improper assembly cannot be legitimately claimed.

Brakes - hydraulic, mechanical:

The warranty covers manufacturing and material defects. In particular, damage caused by accident, collision, fall, neglect of maintenance, improper maintenance or repair or any modification or intervention in the design of the brakes is not covered by the warranty. For example, leakage of the brake system or poor material and workmanship may be considered a legitimate claim.

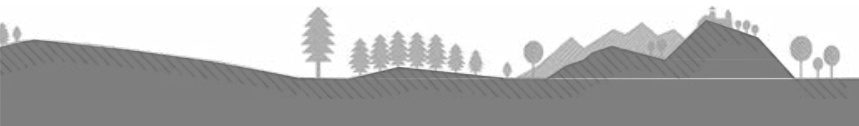

Clicks: A legitimate complaint can be accepted as e.g. a broken crank due to poor casting, a loose converter on the crank, a bad hole including the thread on the crank, crooked converters. Routine clearance adjustments are not covered by the warranty. Here- formed threads on the crank caused by improper assembly and normal wear and tear of the gearboxes due to operation are considered as unauthorized claims. Damage to the quadrant on the cranks by loosening of the bolt holding the crank on the axle is also not eligible for claim. Worn bearing raceways and corroded parts are not covered by the warranty. The purchaser is obliged to regularly inspect and respond to any loosening in a timely manner.

Pedals:

The warranty covers manufacturing and material defects. Wear and tear caused by operation, loosening or breaking of cage joints or bending caused by impact or dropping are not covered by the warranty. Pedal noise and clearance adjustment cannot be accepted as a warranty defect in the warranty claim procedure, but are subject to after-sales service. Damage to bearings due to water and dirt ingress (improper maintenance) or bending or loosening of the axle cannot be legitimately claimed.

Shift levers, shifter and derailleur:

The warranty covers manufacturing and material defects. The warranty does not cover adjustments. Storage, handling and driving may change the setting and adjustments are part of normal maintenance of the product and are not subject to warranty. Mechanical damage caused by dropping (bumping) or tearing of the mechanism due to rough or unprofessional handling is also not covered by the warranty.

The chain:

The warranty covers manufacturing and material defects, e.g. cell breakage. The warranty does not cover, for example, normal wear and tear caused by the carriage (e.g. pulling out), chain breakage due to insensitive or unprofessional shifting (e.g. disconnection at the pin) or damage caused by neglected or unprofessional maintenance (e.g. corrosion, seizing due to dirt, etc.).

Saddle, seatpost:

The claim does not apply to grooves caused by shifting of the seatpost in the seat tube. A claim for a seat tube cannot be accepted if the seat tube has been extended beyond the maximum extension mark. The warranty cannot be claimed for bending of the seatpost caused by an accident or overloading after a jump, bending of the saddle rails, cracked shell, tearing of the saddle cover, etc.

Battery and charger: The battery is guaranteed for 12 months from the date of sale. For example, loss of battery capacity during the first year of use below 70% of the manufacturer's stated capacity may be accepted as a legitimate claim. The warranty does not cover defects caused by neglected maintenance and "undercharging" of the battery during non-use of the e-bike. The battery warranty is void if the battery pack has been penetrated or otherwise tampered with, or if any changes or modifications have been made to the battery pack.

Display and cabling:

For example, a manufacturing and material defect in the display and cabling can be recognised as a legitimate complaint. A claim for a non-functioning display or cabling can be accepted if the display or cabling stops working during the warranty period. The warranty does not cover any mechanical damage, a cracked display or display holder, or a broken or bent connector.

The engine:

The warranty covers manufacturing and material defects. E.g. mechanical damage, damage caused by improper installation or maintenance, damage caused by the operation of the bike or damage to the engine due to water ingress (see user manual) cannot be accepted as a legitimate claim. The engine warranty is void if the engine casing has been penetrated or otherwise tampered with, or any changes or modifications have been made to the engine.

The electrical system of the bike:

Contact of the electrical system with water must be prevented (see user manual). In the event of contact between the electrical system and water, the water must be completely removed immediately and the electrical system checked and the electrical contacts treated with a suitable product.

COMPLAINT PROCEDURE

Always claim the e-bike or battery from your dealer. When making a claim, please present the proof of purchase, the warranty card with the confirmed warranty inspection and the serial numbers of the frame and battery. Tell your dealer the reason for the claim and a description of the fault.

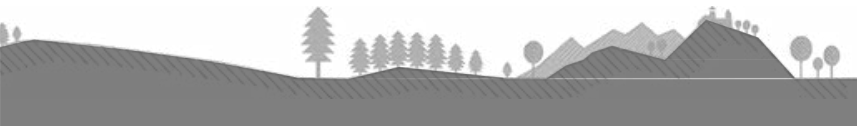

5.2. WARRANTY INSPECTION

In order for the warranty to be granted, the buyer is obliged to take the e-bike to an authorised service centre for a professional warranty service (free of charge). A list of service centres is available at www.autokelly.cz, if necessary contact the dealer's branch.

The warranty service must be carried out within **30 days** after the purchase and use of the e-bike, but no later than after **200 km**.

On the following page is a coupon for a free warranty service. The service department will confirm the record of the warranty inspection for the purpose of any claims in the user manual. The voucher is then sent to the electric bike dealer. If the warranty inspection is not carried out within the above mentioned period, the warranty entitlement will expire.

EasyBike e-bikes are subject to technical development, all information and images are subject to change without notice.

5.3. WARRANTY SHEET

AUTO KELLY a.s. provides a quality guarantee for 24 months (hereinafter referred to as the "guarantee") from the date of delivery to the buyer. The warranty is provided in accordance with the provisions of Section 2113 et seq. of Act No. 89/2012 Coll., Civil Code, as amended. The battery is warranted for a period of 12 months from the date of sale. The warranty applies in particular to defects caused by poor quality material, manufacturing defects and hidden defects. The warranty does not cover the natural loss of battery capacity, which is a standard part of the battery's lifetime. Thus, a battery whose capacity does not fall below 70% of its original value during the warranty period is considered to be free from defects. The warranty on the battery is void if the warranty inspection has not been carried out, or if the defect in the electric bike is caused in particular by mechanical damage, improper handling, improper use, neglected maintenance, external events (natural disaster, accident and other circumstances vis maior) or if the product has been retrofitted in an unprofessional manner.

On behalf of the EasyBike team, we wish you many happy miles.